

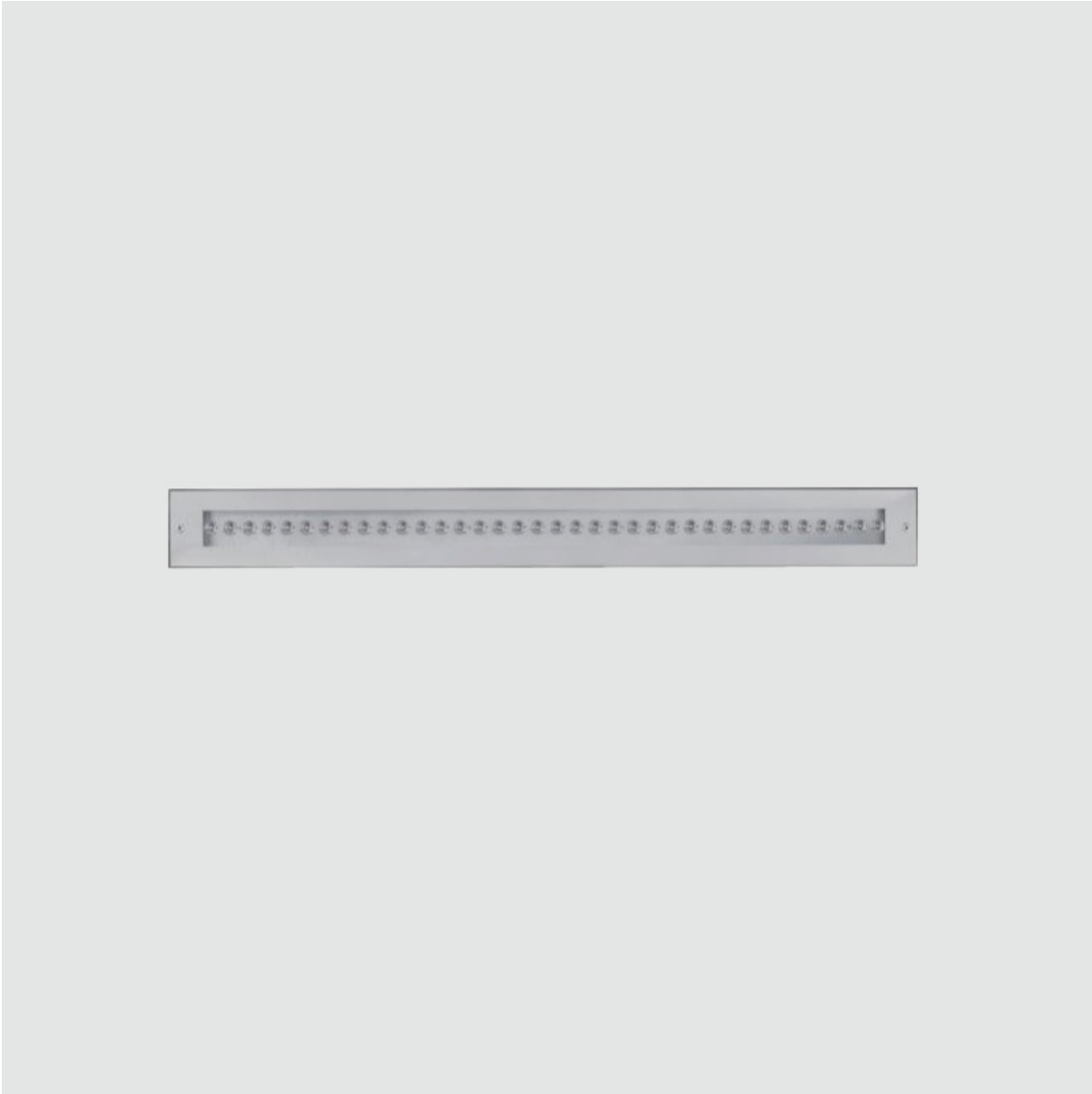

IP 67



TECHNICAL DATA

TETRA RECESSED 360 / 900 - IP65/IP67 - IK 10				
	Supply	Load (Kg)	Class	Weight
LED white - 7.3W	120/277V - 0/50/60Hz	500 Kg	⊕	2.8 Kg
LED white - 9.8W	120/277V - 0/50/60Hz	500 Kg	⊞	2.8 Kg
LED white - 13.5W	120/277V - 0/50/60Hz	500 Kg	⊕	2.8 Kg
LED RGBW - 11.5W	500mA	500 Kg	⊞	2.8 Kg
LED white - 21W	120/277V - 0/50/60Hz	1500 Kg	⊕	5.0 Kg
LED white - 47W	120/277V - 0/50/60Hz	1500 Kg	⊞	5.0 Kg
LED RGBW - 35W	500mA	1500 Kg	⊞	5.0 Kg

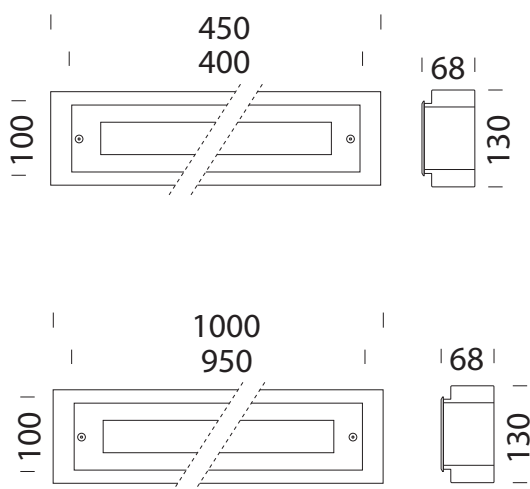

INSTALLATION

- Position the counter-case as to keep the upper edge of the ring flush with the finished floor

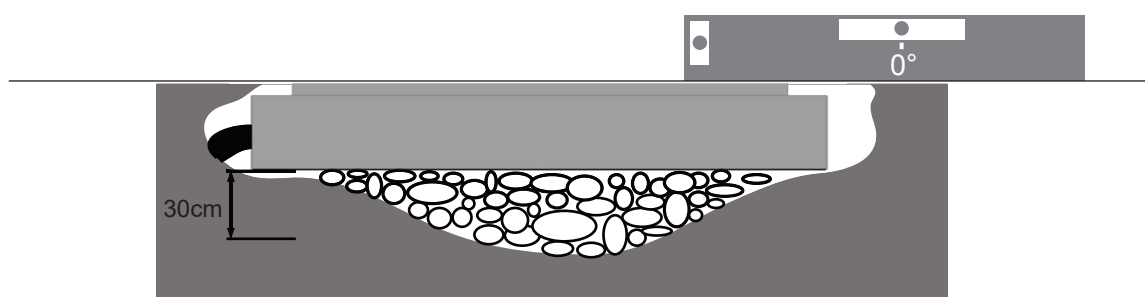

- To fix the counter- case to the ground, do not use products that block the dispersion of heat, such as resins or foams.
- The correct installation foresees a gravel drainage bed of 30 cm at the base of the counter-case.

INSTALLATION

TETRA LED on - off

Connector not supplied

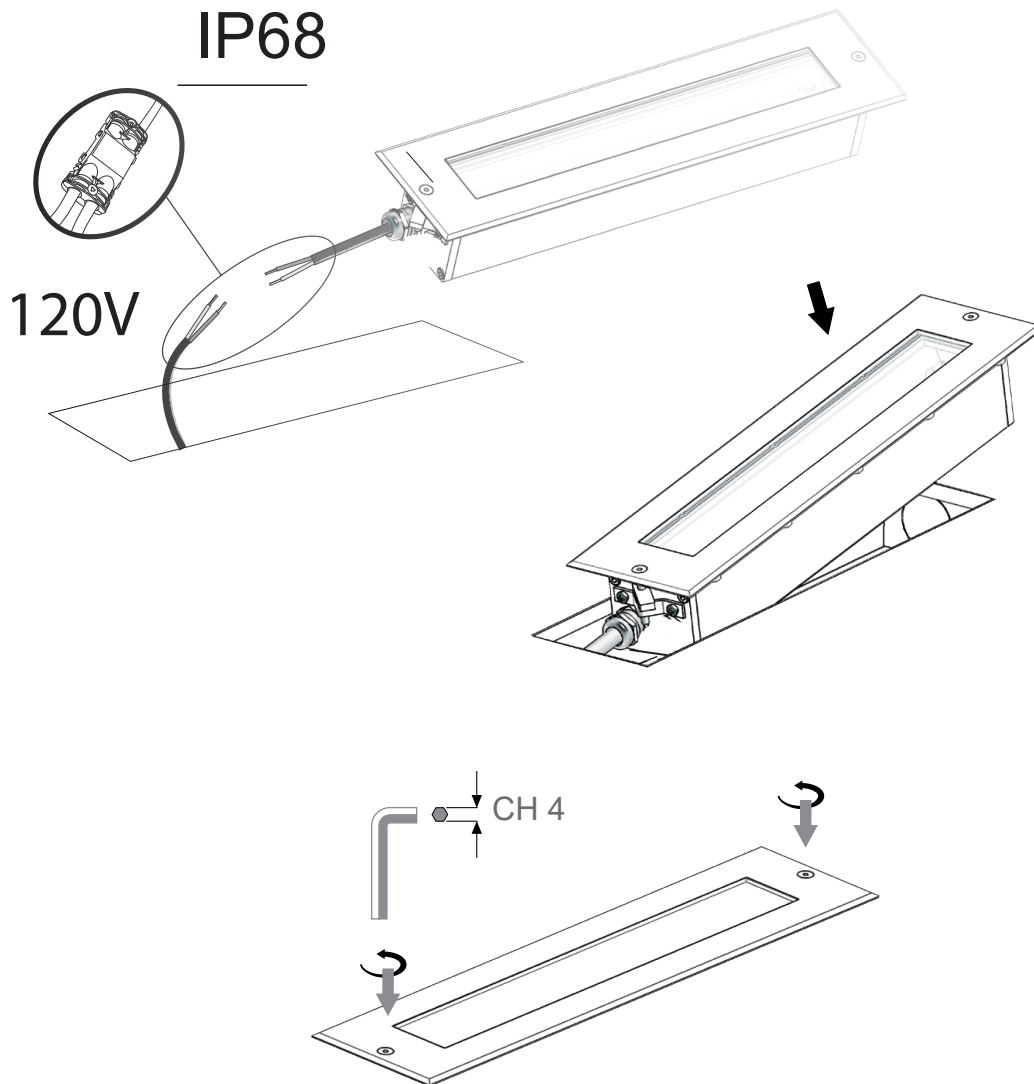

INSTALLATION

TETRA LED RGBW

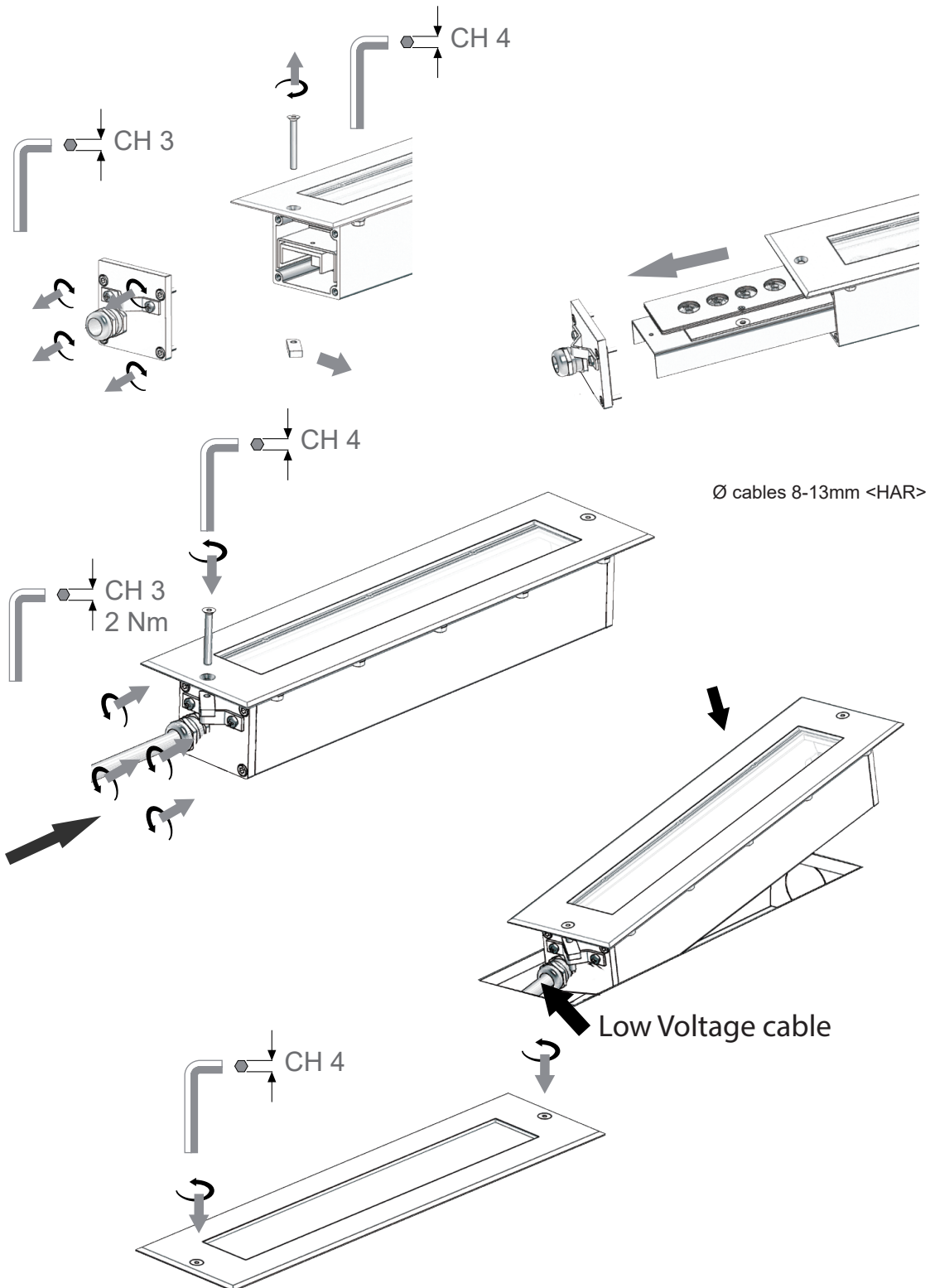

INSTALLATION

OPTIONAL - Remote Driver

Connector not supplied

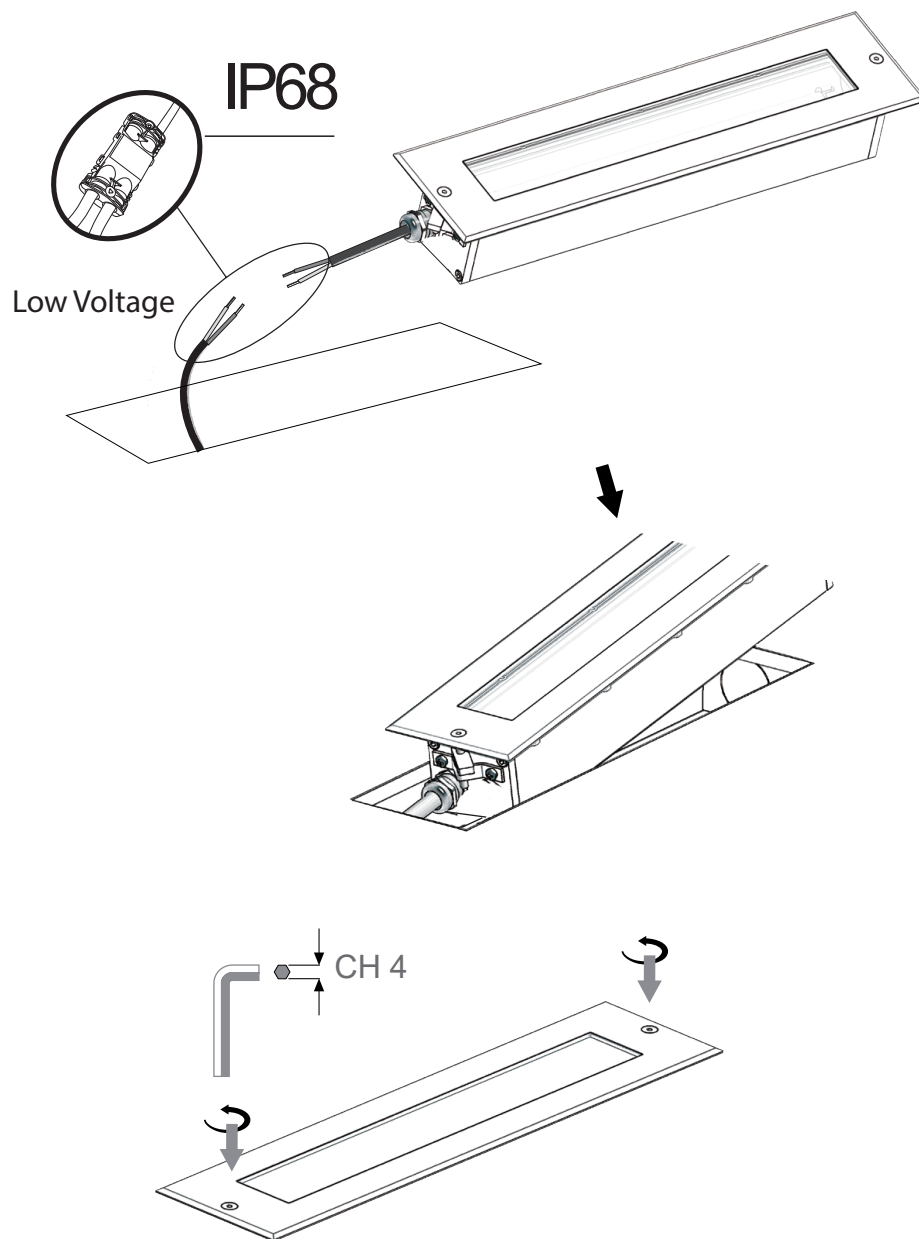

SAFETY AND WARNINGS FOR INSTALLATION



LED MODULE



CAUTION: Make sure that the lines are protected from over-voltage.



Do not look into the beam. LED-Module Risk group GR2<60cm. In case of malfunctions with the LED module, please contact Zaneen. The light source contained in this appliance must only be replaced by the manufacturer or his service agent or similarly qualified personnel.



We do not recommend switching on the fitting during the day with strong solar radiation

Do not put device in contact with aggressive chemical substances, such as fertilizers, etc.



Keep the product clean

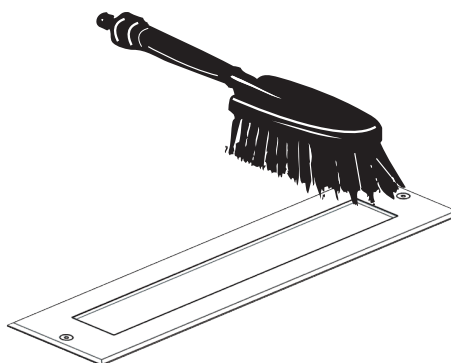

SAFETY AND WARNINGS FOR INSTALLATION

- Installation and start-up must be carried out by qualified personnel only
- Carry out operations on device only with device disconnected from power supply.
- Connect to mains following the installation regulations in force.
- Do not remove power cable.
- If the external flexible cable or cord of this luminaire is damaged, it shall be exclusively replaced by the manufacturer or his service agent or a similar qualified person in order to avoid a hazard.
- Connection to the mains must be performed with certified screw connectors, 250V, 3 x 2.5 mm², 3 x 1.5 mm², 2 x 2.5 mm² or 2 x 1.5 mm², in branch box with protection level IP 68.
- Replace gasket at every lamp change.

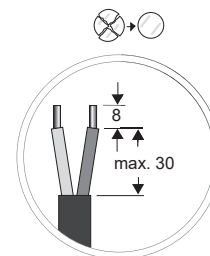

Suggestions on keeping the product: Keep installation instructions in the event of maintenance or disassembly operations, or make them available for the personnel in charge.

EN 60598-2-13

Categories

1. In areas normally not accessible.
2. In areas with limited access (for example reserved for pedestrians and bikers).
3. In all other accessible areas (for example on garage ramps, parking lots, etc.).
4. As above, but in areas where snow machines and/or unfreezing agents are used.
5. In particular areas (where operating temperatures can cause damages, for example in areas for children, in swimming pools, etc.)

IMPORTANT

Post Sales Support HQ 1-800-388-3382 support@zaneen.com



EN

- Installation and electrification must be carried out by a qualified electrician, only.
- Observe all relevant building codes and regulations.
- Prior to installation or repair: disconnect power; it is the installer's responsibility to ensure for all electrical, mechanical and thermal compatibility.
- The LED light source contained in this fixture shall only be replaced by Zaneen, or a person approved by Zaneen.
- Recommendations: Keep the instruction sheet(s) in the event of maintenance and/or disassembly.

Access detailed specification sheets and the warranty policy on the product page at zaneen.com.

FR

- L'installation et l'électrification doivent être effectuées uniquement par un électricien qualifié.
- Respectez tous les codes du bâtiment et réglementations en vigueur.
- Avant l'installation ou la réparation: débranchez l'alimentation électrique; Il incombe à l'installateur des'assurer de la compatibilité électrique, mécanique et thermique.
- La source de lumière LED contenue dans ce luminaire ne doit être remplacée que par Zaneen, ou une personne approuvée par Zaneen.
- Recommandations: Conservez la (les) fiche (s) d'instructions en cas de maintenance et / ou de démontage

Accéder aux fiches techniques détaillées et à la politique de garantie sur la page du produit sur zaneen.com